

## FLOOR DRAIN – Vertical short floor drain





**Part No.**  
**141869**

**Type S10S20**

100mm diameter outlet with hinged Heelguard, 200mm x 200mm grate

### Product Features

#### 1. Stainless steel height adjustable assembly with lockable hinged Heelguard grate secured with M6 Hex socket screws

-  Load Class L15 (EN 1253), similar to Class A10kN (AS 3996)
-  Grates designed to resist the penetration of a 8mm heel. ASME A112.6.3 (Section 7.12) compliant – American high heel Standard
-  AS 3996 (Clause 3.3.5) compliant for surface openings in pedestrian areas
-  AS 1428.2 (Clause 9c) compliant for wheelchair and walking cane safety
-  AS 3996 (Clause 3.3.6) compliant for bicycle tyre penetration resistance

#### 2. Cast iron body

- Cast iron clamp ring (secured with 3 x M8 Hex head bolts) incorporates weep holes to ensure integrity of rolled waterproof membrane
- Nitrile rubber seal for push-fit connection to suit PVC and HDPE pipe

#### 3. Hydraulic data

- Intake area: 5,503 mm<sup>2</sup>
- 2.24 L/s (based on 20mm head of water)

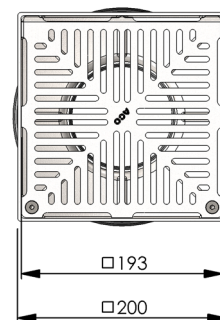
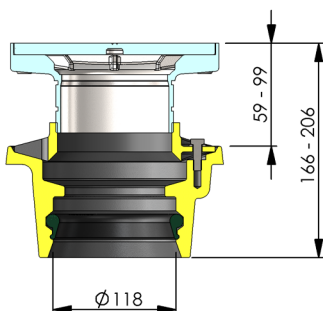
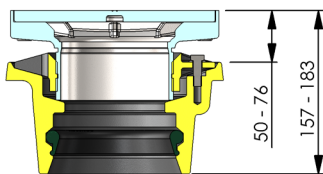
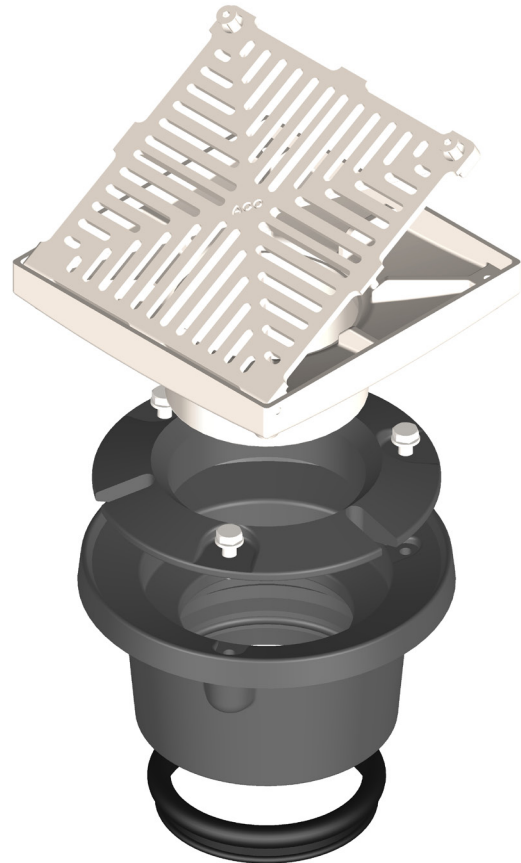

**Note:** All dimensions are in mm

ACO Specification Information

## Specification Clause

This floor drain shall be ACO Wexel Type S10S20 (Part No. 141869). The drain grate shall be Heelguard, 200mm x 200mm square grate (hinged) available with an optional removable strainer (Part No. 141920). The drain body is to suit a 100mm diameter vertical outlet.

### Materials and Design

The grate shall be cast stainless steel, lockable with 2 x M6 Hex socket screws. The grate shall be hinged.

For strength and pedestrian safety, the grate shall be designed to meet load class L15kN (EN 1253), comply with AS 1428.2 (Clause 9c), AS 3996 (Clause 3.3.5 and 3.3.6) and ASME A112.6.3 (Section 7.12).

The iron body shall have a cast iron membrane clamp ring (secured with 3 x M8 Hex head bolts) incorporating weep holes. For push-fit pipe connection, the body shall have a nitrile rubber seal.

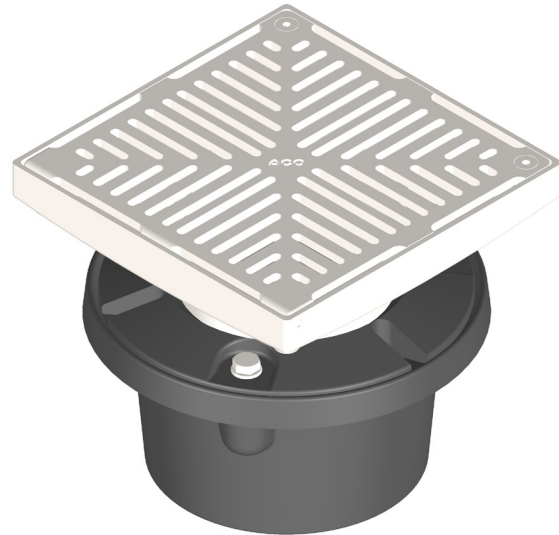

## General Installation Illustration

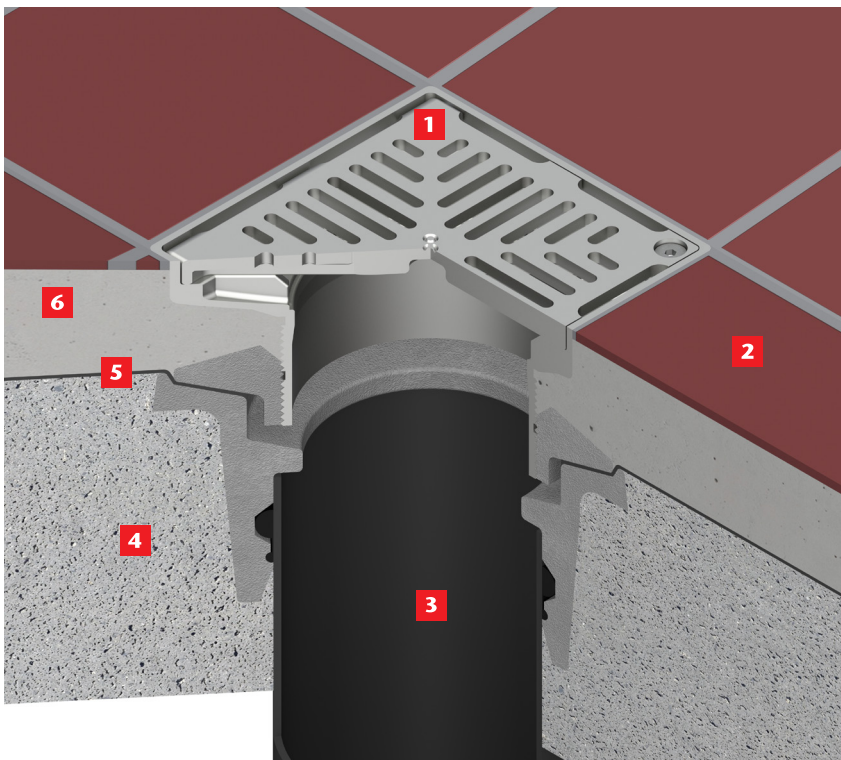

### Full bodied vertical short floor drain installed in tiled floor

- 1** Floor drain – S10S15 shown
- 2** Glue fixed tile
- 3** Outlet pipe – HDPE or PVC
- 4** Concrete slab
- 5** Waterproof membrane
- 6** Screed/mortar

**Note:** The illustration is shown for guidance only and shows a typical drain and not necessarily the specific type described on the data sheet.

For downloadable drawings, visit [www.acowexel.com.au](http://www.acowexel.com.au)

### ACO Polycrete Pty Ltd, Australia

Ph: 1300 765 226  
[www.acowexel.com.au](http://www.acowexel.com.au)  
[sales@acoaus.com.au](mailto:sales@acoaus.com.au)

### ACO Limited, New Zealand

Ph: 0800 448 080  
[www.acowexel.co.nz](http://www.acowexel.co.nz)  
[sales@aconz.co.nz](mailto:sales@aconz.co.nz)

© August, 2014 ACO Polycrete Pty Ltd. All reasonable care has been taken in compiling the information in this document. All recommendations and suggestions on the use of ACO products are made without guarantee since the conditions of use are beyond the control of the company. It is the customer's responsibility to ensure that each product is fit for its intended purpose and that the actual conditions are suitable. ACO Polycrete Pty Ltd. pursues a policy of continuous product development and reserves the right to amend specifications without notice.

