

ROOF DRAIN – Dome Grate

Part No.
141915

Type R10PD
100mm diameter outlet with dome grate

Product Features

1. Hot dip galvanised iron lockable grate secured with M12 Hex head socket screw

- Load Class H1.5kN (EN 1253), non trafficable

2. Cast iron body

- Cast iron clamp ring (secured with M6 Hex head bolt) incorporates weep holes to ensure integrity of rolled waterproof roof membrane
- Integral puddle flange incorporates weep holes to ensure integrity of subsurface waterproof (liquid) membrane
- Nitrile rubber seal for push-fit connection to suit all types of drainage pipe

3. Hydraulic data

- Intake area: 36,576 mm²
- For flow rates, contact ACO

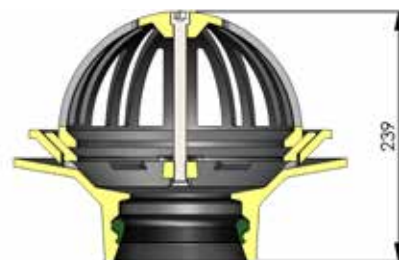
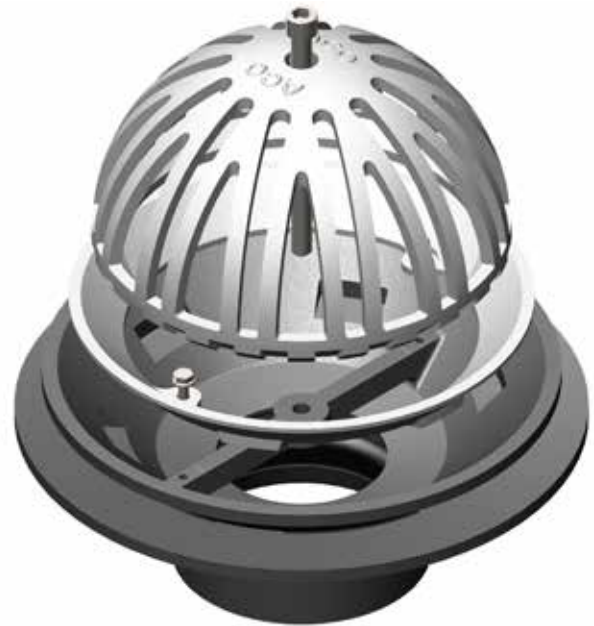

ACO Specification Information

Note: All dimensions are in mm

Specification Clause

This roof drain shall be ACO Wexel Type R10PD (Part No. 141915): 100mm diameter outlet with dome grate.

Materials and Design

The grate shall be hot dip galvanised iron, lockable with M12 Hex head socket screw.

The iron body shall have a cast iron membrane clamp ring (secured with M6 Hex head bolt) and puddle flange both incorporating weep holes.

For push-fit pipe connection, the body shall have a nitrile rubber seal.



General Installation Illustration

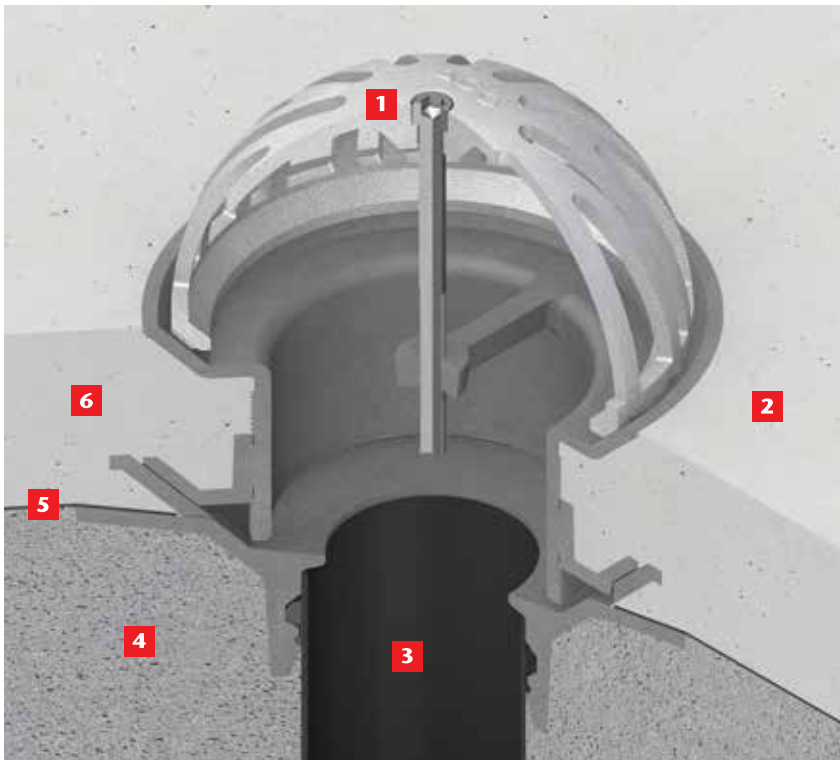

Roof drain with dome grate

- 1** Roof drain – R10PDE shown
- 2** Topping screed
- 3** Outlet pipe – HDPE or PVC
- 4** Concrete slab
- 5** Paintable waterproof membrane
- 6** Screed/mortar

Note: The illustration is shown for guidance only and shows a typical drain and not necessarily the specific type described on the data sheet.

For downloadable drawings, visit www.acowexel.com.au

ACO Polycrete Pty Ltd, Australia

Ph: 1300 765 226
www.acowexel.com.au
sales@acoaus.com.au

ACO Limited, New Zealand

Ph: 0800 448 080
www.acowexel.co.nz
sales@aconz.co.nz

© August, 2016 ACO Polycrete Pty Ltd. All reasonable care has been taken in compiling the information in this document. All recommendations and suggestions on the use of ACO products are made without guarantee since the conditions of use are beyond the control of the company. It is the customer's responsibility to ensure that each product is fit for its intended purpose and that the actual conditions are suitable. ACO Polycrete Pty Ltd. pursues a policy of continuous product development and reserves the right to amend specifications without notice.

